

1. Non air permeable roof finish such as synthetic slates or profiled metal sheets.
2. Slate / tile battens.
3. Breather membrane < 0.25 MNs/g.
4. 25mm Air gap.
5. 50 x 100mm Overall depth counterbatten (50 +50) fixed at 600mm cr/s.
6. 140mm thk TacMat plus insulation (Compressed to 135mm) Lambda 0.037 W/mK
7. VCL.
8. 30mm RW3 (black tissue faced).
9. Perforated TacTray 90 - 1.00mm gauge.
10. Side flange stitcher screws @ 600mm cr/s.
11. Main fasteners.

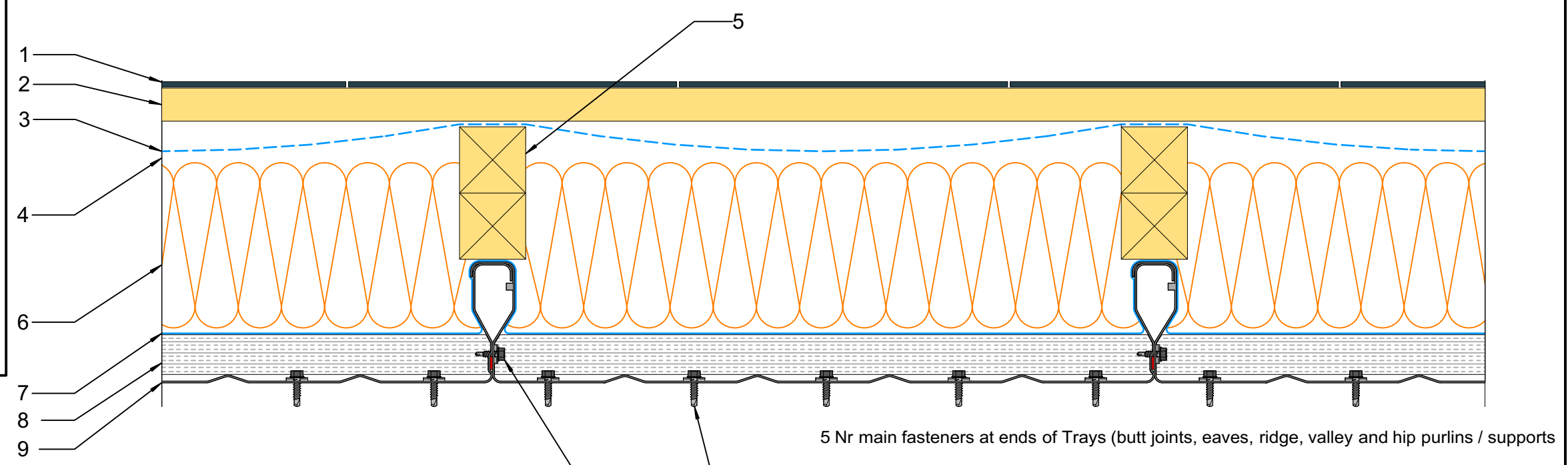

**U Value 0.20 W/m<sup>2</sup>K**

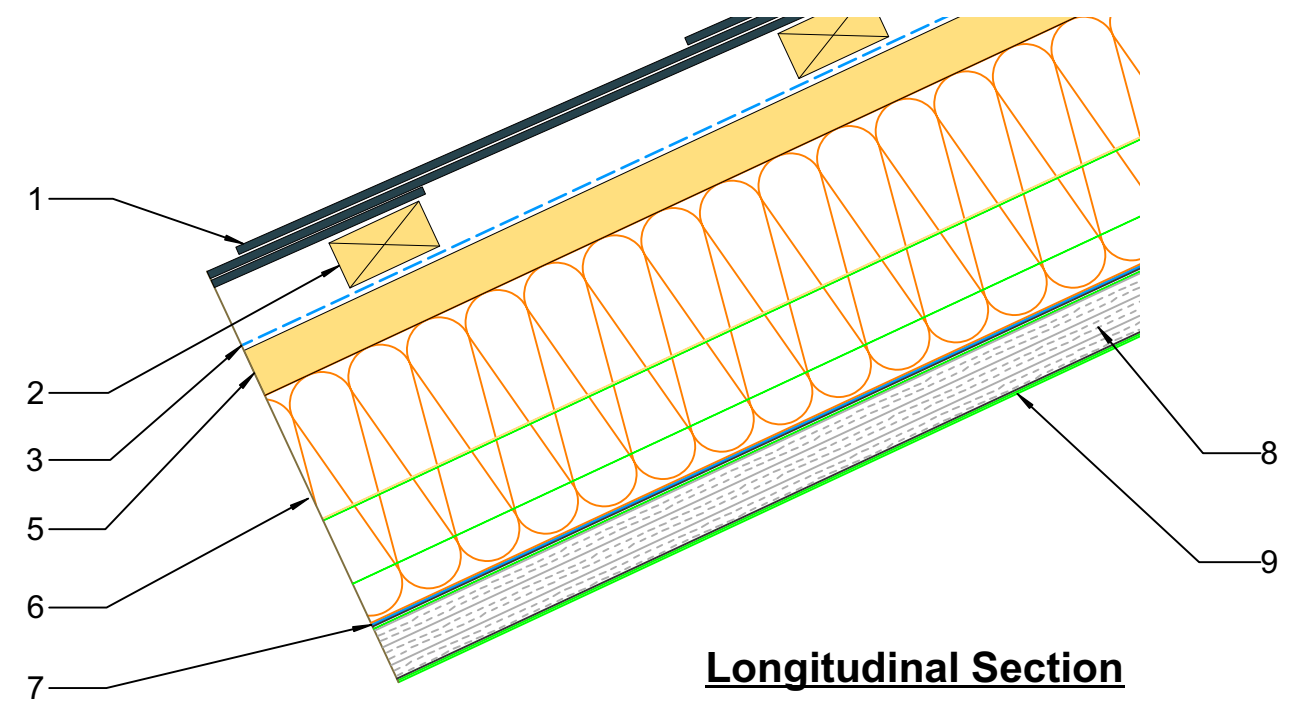
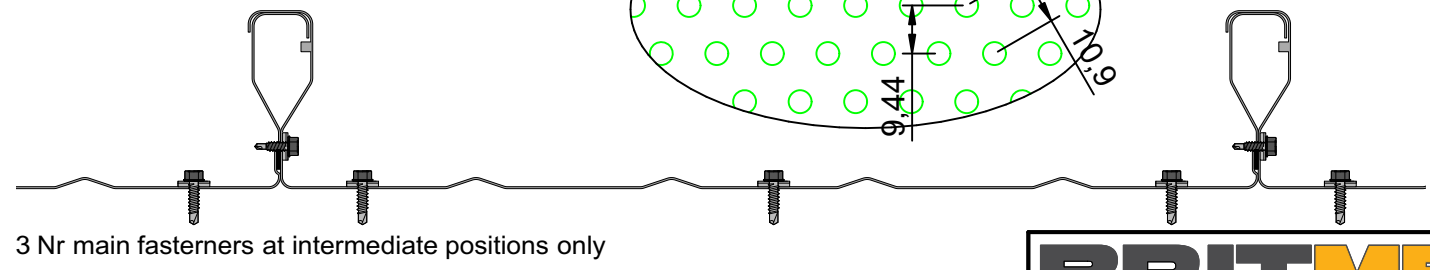
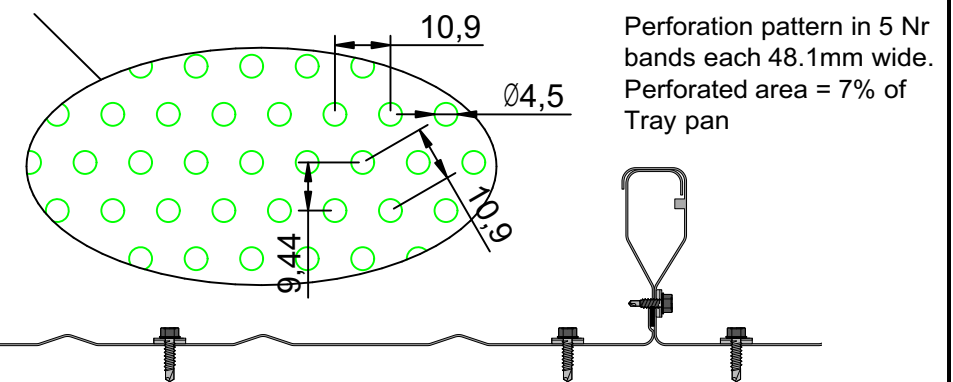
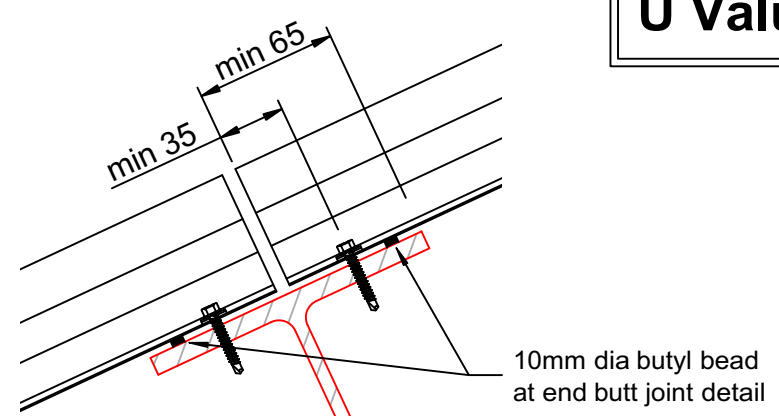

**Predicted Acoustic Performance**

Attenuation:- Rw = 37 dB

Absorption:-

Hz	a
63	0.36
125	0.49
250	0.57
500	0.57
1k	0.63
2k	0.63
4k	0.63

All values derived from acoustic performance modeling software. Physical test performance data are recommended if definitive values are required

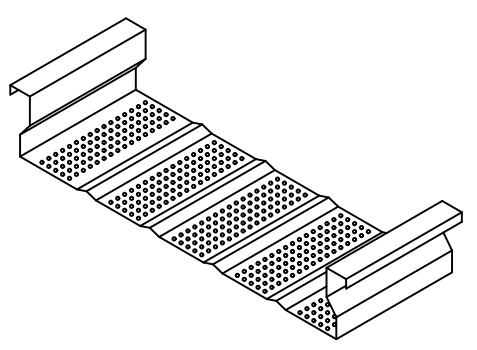

**BRITMET**  
LIGHTWEIGHT ROOFING  
**TacTray 90**

Britmet Lightweight Roofing  
Kingfisher House  
Unit 17  
Overhorpe Road  
Banbury  
OX16 4SX  
Tel: 01295 250998  
Fax: 01295 271068  
email sales@britmet.co.uk  
www.britmet.co.uk

Drawn	Date	Scale
BTD	11/12/19	Do Not Scale

**Revisions**

--	--	--

**Title**  
Britmet Lightweight Roofing  
TacTray 90 - Acoustic Construction Details for  
Non Air Permeable Roof Finishes.

**U Value 0.20 W/m<sup>2</sup>K.**

**DRG No.**  
**TF/TT90/201**