

Britmet Tileform Ltd

Spital Farm
Grimsbury
Banbury

Oxon OX16 8RZ

Tel: 01295 250998 Fax: 01295 271068

e-mail: sales@britmet.co.uk

website: www.britmet.co.uk



Agrément Certificate
89/2272
Product Sheet 1

BRITMET ROOFING SHEETS

BRITMET TILEFORM PANTILE 2000

This Agrément Certificate Product Sheet⁽¹⁾ relates to Britmet Tileform Pantile 2000, preformed coated galvanized steel roofing sheets and accessories for use on timber or steel roof structures with a minimum pitch of 5°.

(1) Hereinafter referred to as 'Certificate'.

CERTIFICATION INCLUDES:

- factors relating to compliance with Building Regulations where applicable
- factors relating to additional non-regulatory information where applicable
- independently verified technical specification
- assessment criteria and technical investigations
- design considerations
- installation guidance
- regular surveillance of production
- formal three-yearly review.



KEY FACTORS ASSESSED

Weathertightness — the product, used with a suitable underlay, has satisfactory resistance to the passage of rain and snow (see section 6).

Strength and stability — the product has satisfactory resistance to the effects of wind loading likely to be met in service (see section 7).

Properties in relation to fire — the product may be unrestricted under the national Building Regulations (see section 8).

Durability — under normal conditions the product will have a service life in excess of 30 years (see section 11).

The BBA has awarded this Certificate to the company named above for the product described herein. This product has been assessed by the BBA as being fit for its intended use provided it is installed, used and maintained as set out in this Certificate.

On behalf of the British Board of Agrément

Date of First issue: 6 March 2014

Originally certificated on 1 August 1989

Simon Wroe
Head of Approvals — Materials

Claire Curtis-Thomas
Chief Executive

The BBA is a UKAS accredited certification body — Number 113. The schedule of the current scope of accreditation for product certification is available in pdf format via the UKAS link on the BBA website at www.bbacerts.co.uk

Readers are advised to check the validity and latest issue number of this Agrément Certificate by either referring to the BBA website or contacting the BBA direct.

British Board of Agrément
Bucknalls Lane
Watford
Herts WD25 9BA

tel: 01923 665300
fax: 01923 665301
e-mail: mail@bba.star.co.uk
website: www.bbacerts.co.uk

©2014

Regulations

In the opinion of the BBA, Britmet Tileform Pantile 2000, if installed, used and maintained in accordance with this Certificate, will meet or contribute to meeting the relevant requirements of the following Building Regulations (the presence of a UK map indicates that the subject is related to the Building Regulations in the region or regions of the UK depicted):



The Building Regulations 2010 (England and Wales) (as amended)

Requirement:	A1	Loading
Comment:		The product can contribute to satisfying this Requirement. See section 7 of this Certificate.
Requirement:	B3(2)	Internal fire spread (structure)
Requirement:	B4(2)	External fire spread
Comment:		The product may be unrestricted under these Requirements. See section 8 of this Certificate.
Requirement:	C2(b)	Resistance to moisture
Comment:		The product can contribute to meeting this Requirement. See section 6 of this Certificate.
Regulation:	7	Materials and workmanship
Comment:		The product is acceptable. See section 11 and the <i>Installation</i> part of this Certificate.



The Building (Scotland) Regulations 2004 (as amended)

Regulation:	8(1)(2)	Fitness and durability of materials and workmanship
Comment:		The product is acceptable. See sections 10, 11 and the <i>Installation</i> part of this Certificate.
Regulation:	9	Building standards applicable to construction
Standard:	1.1(a)(b)	Structure
Comment:		The product can contribute to a construction satisfying this Standard. See section 7 of this Certificate.
Standard:	2.1	Compartmentation
Standard:	2.2	Separation
Comment:		The product can contribute to satisfying these Standards, with reference to clauses 2.1.15 ⁽²⁾ , 2.2.7 ⁽²⁾ and 2.2.10 ⁽¹⁾ . See section 8 of this Certificate.
Standard:	2.8	Spread from neighbouring buildings
Comment:		The product may be unrestricted under this Standard, with reference to clause 2.8.1 ⁽¹⁾⁽²⁾ . See section 8 of this Certificate.
Standard:	3.10	Precipitation
Comment:		The product can contribute to satisfying this Standard, with reference to clauses 3.10.1 ⁽¹⁾⁽²⁾ and 3.10.8 ⁽¹⁾⁽²⁾ . See section 6 of this Certificate.
Standard:	7.1(a)	Statement of sustainability
Comment:		The product can contribute to meeting the relevant requirements of Regulation 9, Standards 1 to 6 and therefore will contribute to a construction meeting a bronze level of sustainability as defined in this Standard.
Regulation:	12	Building standards applicable to conversions
Comment:		Comments made in relation to the product under Regulation 9, Standards 1 to 6 also apply to this Regulation, with reference to clause 0.12.1 ⁽¹⁾⁽²⁾ and Schedule 6 ⁽¹⁾⁽²⁾ . (1) Technical Handbook (Domestic). (2) Technical Handbook (Non-Domestic).



The Building Regulations (Northern Ireland) 2012

Regulation:	23(a)(i)(iii)(b)(i)	Fitness of materials and workmanship
Comment:		The product is acceptable. See section 11 and the <i>Installation</i> part of this Certificate.
Regulation:	28(b)	Resistance to moisture and weather
Comment:		The product can contribute to meeting the requirements of this Regulation. See section 6 of this Certificate.
Regulation:	D1	Stability
Comment:		The product can contribute to satisfying this Regulation. See section 7 of this Certificate.
Regulation:	35(2)	Internal fire spread – Structure
Regulation:	36(b)	External fire spread
Comment:		The product may be unrestricted under these Regulations. See section 8 of this Certificate.

Construction (Design and Management) Regulations 2007

Construction (Design and Management) Regulations (Northern Ireland) 2007

Information in this Certificate may assist the client, CDM co-ordinator, designer and contractors to address their obligations under these Regulations.

See sections: 1 *Description* (1.2) and 3 *Delivery and site handling* (3.1) of this Certificate.

Additional Information

NHBC Standards 2014

NHBC accepts the use of Britmet Tileform Pantile 2000, provided it is installed, used and maintained in accordance with this Certificate, in relation to *NHBC Standards, Part 7 Roofs, Chapter 7.2 Pitched roofs*.

CE marking

The Certificate holder has taken the responsibility of CE marking the product in accordance with harmonised European Standard BS EN 14782 : 2006. An asterisk (*) appearing in this Certificate indicates that data shown are given in the manufacturer's Declaration of Performance.

Technical Specification

1 Description

1.1 Britmet Tileform Pantile 2000 roofing sheets are pressed from 0.9 mm thick galvanized steel sheet (DX51D + Z275 to BS EN 10346 : 2009) to a shape simulating conventional tiles. The weather face is primed with a polyester primer and finished with a mineral-filled acrylic coating to a minimum thickness of 250 μm (see Figure 1). The underside of the product is coated with either a 7 μm thick epoxy or a minimum 80 μm thick bitumen acrylic.

Figure 1 Section through Britmet Tileform Pantile 2000

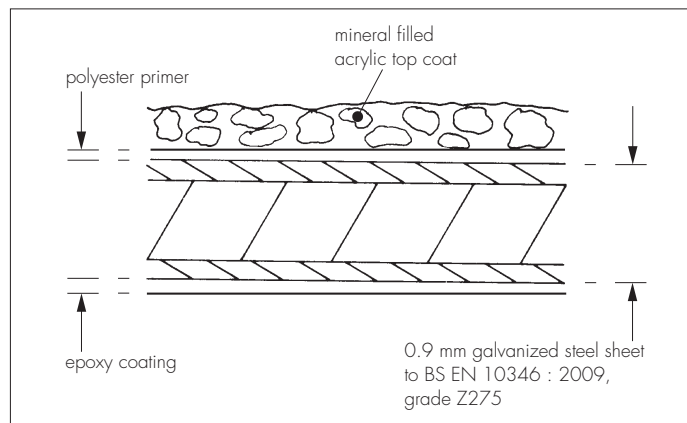

1.2 The product is available in six colours (terracotta, antique red, mid grey, sage green, tudor brown and charcoal) and has the following specification (see Figure 2):

thickness of sheet (mm)	0.9
weight of sheet ($\text{kg}\cdot\text{m}^{-2}$)	11,9
width of sheet (m)	1.08
cover width (m)	1.04
max length of sheet ⁽¹⁾ (m)	6.0
module width	130
module course height (mm)	300
side lap (mm)	40
end lap (mm)	300.

(1) Supplied cut to length, avoiding the need for end laps. Lengths up to 10 m can be supplied for special orders.

Figure 2 Britmet Tileform Pantile 2000 – Dimensions

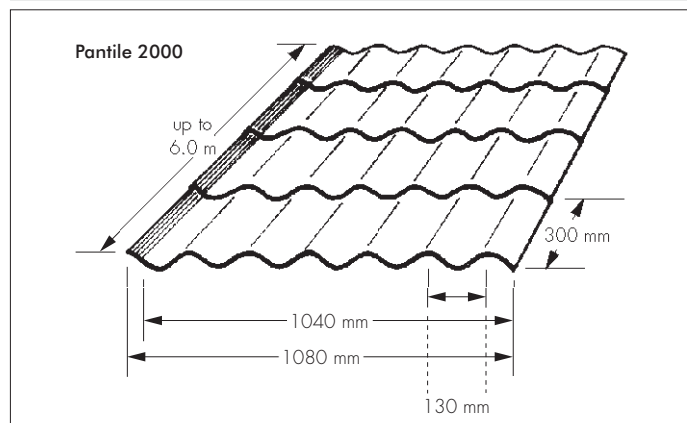

1.3 Accessories (available in 2 m lengths as standard — other lengths are available to order) with the same coating specification as the product are:

- ridge cap
- eaves soffit and fascia flashing
- parapet flashing
- standard eaves flashing
- apron flashing
- verge flashing
- soffit and fascia flashing
- standard bargeboard
- valley.

1.4 Other accessories include:

- fixings — cadmium electroplated and dichromate passivated carbon steel self-drilling screws with a self-sealing washer and plastic (ethylene-vinyl acetate) cap
- touch-up kit — a bitumen primer and acrylic top coat for use at cut edges and surface repairs
- butyl strip sealant — in 6 mm and 10 mm diameters, used for side laps
- eave comb filler blocks — used at eaves, ridges, valleys and hips to prevent penetration of large items while still providing adequate ventilation.

1.5 Other accessories available, but outside the scope of this Certificate, include:

- roof ventilation units
- gas vent ridge terminals.

2 Manufacture

2.1 Degreased galvanized steel sheets are cut to the required length and pressed in a two stage operation to form the profiled roofing sheet. Each face of the sheet is sprayed with a minimum thickness of 80 µm of bitumen acrylic primer and oven cured. The weather face is then coated with a minimum thickness of 250 µm of mineral filled styrene acrylic copolymer paint and the completed sheets are cured in a heated environment. Accessories are produced from the same type of sheet by pressing.

2.2 As part of the assessment and ongoing surveillance of product quality, the BBA has:

- agreed with the manufacturer the quality control procedures and product testing to be undertaken
- assessed and agreed the quality control operated over batches of incoming materials
- monitored the production process and verified that it is in accordance with the documented process
- evaluated the process for management of nonconformities
- checked that equipment has been properly tested and calibrated
- undertaken to carry out the above measures on a regular basis through a surveillance process, to verify that the specifications and quality control operated by the manufacturer are being maintained.

3 Delivery and site handling

3.1 The sheets are wrapped in polyethylene foam and delivered to site on pallets of up to 30 with a temporary weatherproof cover. The pallets are unloaded using fork-lift trucks.

3.2 A label bearing the handling and storage instructions is affixed inside each pallet load.

3.3 The products bear the BBA identification mark incorporating the number of this Certificate.

3.4 During transport the edges and corners of the sheets must be protected to prevent damage.

3.5 When on site the pallets should be stored on a firm, dry base away from the possibility of damage, covered to prevent water ingress, and as close as possible to the building where they are to be installed. To prevent damage to the coating on installation, individual sheets should be lifted from the stack rather than dragged across it.

Assessment and Technical Investigations

The following is a summary of the assessment and technical investigations carried out on Britmet Tileform Pantile 2000.

Design Considerations

4 Use

4.1 Britmet Tileform Pantile 2000 roofing sheets are satisfactory for use as a roofing system on a timber or steel structure with a minimum pitch of 5°.

4.2 On roof pitches from 5° to 10°, the product should preferably be laid using only single sheets from the ridge to the eaves. Where this is not possible, an overlap of 300 mm (one module) is required and is sealed using two 6 mm diameter beads of butyl strip sealant.

4.3 On roof pitches from 5° to 10°, the side overlaps are sealed with a continuous 10 mm diameter bead of butyl strip sealant with stitching screws every 600 mm (ie every alternate module). On roof pitches greater than 10°, the side overlap is sealed with a continuous 6 mm diameter bead of butyl strip sealant with stitching screws every 900 mm (ie every third module).

4.4 Normal precautions in design are necessary to shed water clear of the surface to avoid the formation of drain marks.

4.5 In coastal areas, where the roofing sheets may be exposed to wind-driven spray, the exposed underside of the lower courses of sheets may suffer corrosion. To prevent this, the eaves should be detailed to minimise the extent of the exposed area.

5 Practicability of installation

The product is designed to be installed by a competent general builder, or contractor, experienced with this type of product.

6 Weathertightness



The product, when installed in accordance with this Certificate and with a suitable underlay, has satisfactory resistance to the passage of rain and snow.

7 Strength and stability



7.1 The product has adequate resistance to the effects of wind suction likely to be met in service.

7.2 The tilesheets weigh considerably less than conventional roofing materials and the roof substructure must be securely attached to the structure of the building to prevent wind uplift under adverse conditions.

8 Properties in relation to fire



8.1 When tested to the requirements of BS EN 13501-5 : 2005, a terracotta coloured product achieved a B_{ROOF}(t4) rating*.

8.2 This performance may not be achieved by all colours of the product and the designations of a particular colour should be confirmed by test or assessment, as required by the relevant national Building Regulation.

9 Resistance to damage

9.1 The product has good resistance to deformation from heavy impacts and maintenance traffic.

9.2 Impacts or maintenance traffic may damage the coating and affect the appearance of the product. Damaged areas must be repaired as soon as possible (see section 10.2).

10 Maintenance



10.1 If regular access to the roof is required (eg for equipment maintenance) a catwalk should be provided to prevent damage to the surface. For occasional roof maintenance work, roof ladders or crawling boards should be used but care is still required to prevent damage.

10.2 Small damaged areas of the coating may be treated using the touch-up kit available from the Certificate holder. The roof should be cleared of leaves and other organic matter at regular intervals.

11 Durability



11.1 The acrylic coating and galvanizing will protect the steel substrate against corrosion and will give the product a service life in excess of 30 years.

11.2 The colour stability of the tilesheet is satisfactory but a noticeable colour difference may develop on damaged areas recoated with touch-up paints.

12 Reuse and recyclability

The product comprises steel, which can be recycled.

Installation

13 General

13.1 The standard of Installation of Britmet Tileform Pantile 2000 should comply with the requirements of BS 8000-6 : 1990.

13.2 The timber or steel frame on which the product is to be installed must be designed and built in accordance with BS 5427-1 : 1996.

13.3 The roof construction must be sufficient to resist the loadings detailed in Eurocodes BS EN 1991-1-1 : 2002, BS EN 1991-1-4 : 2005, and their respective UK National Annexes, or BS 6399-1 : 1996 and BS 6399-2 : 1997. The maximum permitted rafter spacing depends on the size of the batten used, as shown in Table 1. The roof construction should be in accordance with the requirements of BS 5534 : 2003.

Table 1 Permitted rafter or roof truss spacing

Batten size (mm)	Maximum rafter spacing (mm)
50 x 75	1500
50 x 50	1200
50 x 38	600
38 x 38	450

13.4 Rafters and roof trusses must be securely tied to the building structure with galvanized steel straps complying with BS EN 1996-1-1 : 2005, BS EN 1991-2 : 2006 or PD 6697 : 2010.

13.5 The roof and batten spaces must be adequately ventilated in accordance with BS 5250 : 2011.

13.6 The underlay must be to BS 8747 : 2007, Annex B, Type 1F or 5U, or covered by an Agrément Certificate and installed in accordance with that Certificate.

13.7 To prevent electrochemical corrosion, direct contact with copper or its alloys should be avoided and copper roofs should not drain onto the installation.

14 Procedure

14.1 The product must be installed in accordance with the manufacturer's instructions and the conditions set out in this Certificate.

14.2 Installation must always commence from the right-hand verge or hip. From the ridge to the eaves the product is fastened to each purlin through the crown of the profile using the appropriate self-drilling screws (see Table 2) at a rate of three per sheet.

Table 2 Fastening details

Purlin type (thickness)	Fastener ⁽¹⁾
Timber (over 45 mm)	PHT8213 ⁽²⁾ HT82A13 ⁽³⁾
Steel (1.5 mm to 3 mm)	PHT5713 ⁽²⁾ HT57A13 ⁽³⁾
Steel (5 mm to 12 mm)	PM15.4 ⁽²⁾ 15.4 ⁽³⁾

(1) Supplied by Buildex Ltd (alternatives from other reputable suppliers may be used).

(2) With BX22 style cap.

(3) Buildex Tek screws with BX4 cap.

14.3 At the ridge and eaves the roofing sheets are fastened through every alternate profile. For side stitching, the roofing sheets are fastened through every alternate profile to verge rafters.

14.4 Each roofing sheet is securely fastened to the purlins before subsequent sheets are laid. The sheets are overlapped by 40 mm with butyl strip sealant (10 mm diameter bead for pitch angles from 5° to 10° or 6 mm diameter bead for pitch angles greater than 10°) placed along the length of the join. Stitching screws are used (every second module for pitch angles from 5° to 10° and every third module for pitch angles greater than 10°) to pull the sheets together and form a tight lap. The sheets should extend over the eaves by 30 mm.

14.5 Where the length of the roof is greater than the length of a single tilesheet, the eaves roofing sheets are laid and fixed first. The ridge sheets are staggered and lapped over the eaves sheets (75 mm overlap for roof pitches of 10° to 90° and 300 mm for roof pitches of 9° to 5°) and joined together using the overlap screws through alternate profiles. Mitring of the overlaps is performed to reduce the total thickness of sheet which the fixing nails have to penetrate.

14.6 Where required, the roofing sheets and accessories should be carefully cut using non-abrasive tools (eg a nibbler), formed and installed to provide a weathertight finish. Care should be taken to remove swarf and steel cuttings and cut edges should be protected by applying the primer and top coat from the touch-up kit.

14.7 Flashings and ridges must be fastened using the overlap screws and all screws must be covered with plastic caps. Alternatively, the screws may be coated with the touch-up paint.

14.8 Ventilated comb fillers are secured in position along the eaves, ridges, hips and valleys to allow airflow.

15 Tests

Tests were conducted and the results assessed to determine:

- impact resistance
- scratch resistance
- abrasion resistance
- damage in handling
- effect of artificial weathering
- effect of salt spray
- resistance to wind-driven rain.

15.2 An assessment was made of:

- strength of the product including resistance to loading
- weathertightness of the overlaps
- life of the fixings
- compatibility of materials in contact.

16 Investigations

16.1 The manufacturing process was evaluated, including the methods adopted for quality control, and details were obtained of the quality and compositions of materials used.

16.2 An assessment was made of a fire test report to BS EN 13501-5 : 2005.

16.3 A visit was made to a site in progress to assess the practicability of installation and ease of repair.

16.4 Visits were made to established sites to assess the performance in use..

Bibliography

BS 5250 : 2011 *Code of practice for control of condensation in buildings*

BS 5427-1 : 1996 *Code of practice for the use of profiled sheet for roof and wall claddings on buildings — Design*

BS 5534 : 2003 *Code of practice for slating and tiling (including shingles)*

BS 6399-1 : 1996 *Loading for buildings — Code of practice for dead and imposed loads*

BS 6399-2 : 1997 *Loading for buildings — Code of practice for wind loads*

BS 8000-6 : 1990 *Code of practice for slating and tiling of roofs and claddings*

BS EN 1991-1-1 : 2002 *Eurocode 1 : Actions on structures — General actions— Densities, self-weight, imposed loads for buildings*

NA to BS EN 1991-1-1 : 2002 *UK National Annex to Eurocode 1 : Actions on structures — General actions— Densities, self-weight, imposed loads for buildings*

BS EN 1991-1-4 : 2005 *Eurocode 1 : Actions on structures — General actions — Wind actions*

NA to BS EN 1991-1-4 : 2005 *UK National Annex to Eurocode 1 : Actions on structures — General actions — Wind actions*

BS EN 1996-1-1 : 2005 *Eurocode 6 — Design of masonry structures — General rules for reinforced and unreinforced masonry structures*

NA to BS EN 1996-1-1 : 2005 *UK National Annex to Eurocode 6 — Design of masonry structures — General rules for reinforced and unreinforced masonry structures*

BS EN 10346 : 2009 *Continuously hot-dip coated steel flat products — Technical delivery conditions*

BS EN 13501-5 : 2005 *Fire classification of construction products and building elements — Part 5: Classification using data from external fire exposure to roofs tests*

BS EN 14782 : 2006 *Self-supporting metal sheet for roofing, external cladding and internal lining — Product specification and requirements*

17 Conditions

17.1 This Certificate:

- relates only to the product/system that is named and described on the front page
- is issued only to the company, firm, organisation or person named on the front page — no other company, firm, organisation or person may hold or claim that this Certificate has been issued to them
- is valid only within the UK
- has to be read, considered and used as a whole document — it may be misleading and will be incomplete to be selective
- is copyright of the BBA
- is subject to English Law.

17.2 Publications, documents, specifications, legislation, regulations, standards and the like referenced in this Certificate are those that were current and/or deemed relevant by the BBA at the date of issue or reissue of this Certificate.

17.3 This Certificate will remain valid for an unlimited period provided that the product/system and its manufacture and/or fabrication, including all related and relevant parts and processes thereof:

- are maintained at or above the levels which have been assessed and found to be satisfactory by the BBA
- continue to be checked as and when deemed appropriate by the BBA under arrangements that it will determine
- are reviewed by the BBA as and when it considers appropriate.

17.4 The BBA has used due skill, care and diligence in preparing this Certificate, but no warranty is provided.

17.5 In issuing this Certificate, the BBA is not responsible and is excluded from any liability to any company, firm, organisation or person, for any matters arising directly or indirectly from:

- the presence or absence of any patent, intellectual property or similar rights subsisting in the product/system or any other product/system
- the right of the Certificate holder to manufacture, supply, install, maintain or market the product/system
- actual installations of the product/system, including their nature, design, methods, performance, workmanship and maintenance
- any works and constructions in which the product/system is installed, including their nature, design, methods, performance, workmanship and maintenance
- any loss or damage, including personal injury, howsoever caused by the product/system, including its manufacture, supply, installation, use, maintenance and removal
- any claims by the manufacturer relating to CE marking.

17.6 Any information relating to the manufacture, supply, installation, use, maintenance and removal of this product/system which is contained or referred to in this Certificate is the minimum required to be met when the product/system is manufactured, supplied, installed, used, maintained and removed. It does not purport in any way to restate the requirements of the Health and Safety at Work etc. Act 1974, or of any other statutory, common law or other duty which may exist at the date of issue or reissue of this Certificate; nor is conformity with such information to be taken as satisfying the requirements of the 1974 Act or of any statutory, common law or other duty of care.